

PL-LPT-SPT – Static Pressure Probe

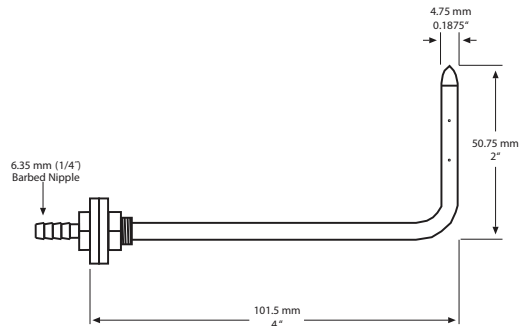

Product Description

The PL-LPT-SPT static pressure tip is ideal for applications such as sensing the static pressure in ventilation ducts as well as the pressure drop across industrial air filters and refrigerant coils. Here the probability of air turbulence requires that the pressure sensing openings be located away from the duct walls to minimize impingement and aspiration, and thus ensure accurate readings. It senses static pressure through radially-drilled holes near the tip and can be used in air flow velocities up to 12,000 FPM. The angled tips have 4" insertion depth. Each has four radially drilled .040" sensing holes. A 3/8" hole is used for mounting in duct.

Technical Specifications

PROBE MATERIAL	Brass
PROBE DIMENSIONS	0.1875" (4.75 mm) Diameter
INSERTION LENGTH	4" (101.5 mm)
BRACKET MATERIAL	Brass

Typical Installation

1. Select an area for the probe 5 to 8 duct diameters from any elbows, obstructions, or significant changes in the duct area.
2. Drill a 0.375" (10 mm) hole
3. Remove nut and one washer and insert the probe.
4. Determine the duct's flow direction and turn probe so the tip is pointing into the flow.
5. Install the unit horizontally to assure accurate velocity readings.
6. Re-install washer and nut and tighten securely.

The PL-LPT-SPT Series has a 1/4" (6.35 mm) OD, barbed fitting for use with 3/8" (9.5 mm) OD tubing. During installation check that there are no sharp bends in the tubing at any connection. Bends and creases may leak overtime as the tubing ages.

