

**HARDWARE GUIDE**  
**DIMENSIONS &**  
**SPECIFICATIONS**

**PROLON**

**REV. 5.2**

***M1000***  
***INTELLIGENT ZONE***  
***CONTROL SYSTEM***

***HEATPUMP***  
***CONTROLLER***

[info@prolon.net](mailto:info@prolon.net)

[www.prolon.net](http://www.prolon.net)

**PROLON**  
**1-877-9PROLON**

**Montréal**

1989 rue Michelin Laval,  
QC H7L 5B7  
TEL: (450) 973-7765 FAX: (450) 973-6186  
1-800-461-1381

## Table of Contents

<b>GENERAL INFORMATION.....</b>	<b>3</b>
PL-M1000 Heatpump Controller .....	3
Description.....	3
General Behaviour.....	3
Operation Sequence .....	4
General.....	4
Occupied Mode .....	4
Unoccupied Mode.....	5
<b>COMPONENTS.....</b>	<b>6</b>
Component Identification .....	6
LEDs and Switches.....	7
LED Descriptions:.....	7
HAND/OFF/AUTO Switches.....	7
Internal Jumpers .....	8
Input and Output Identification .....	9
Addressing Dipswitch Configuration for Network Communication.....	10
<b>INPUTS.....</b>	<b>11</b>
Temperature Sensors .....	11
Room Sensors .....	11
Proof of Fan .....	12
Dry Contact for Clogged Filter or Schedule Override .....	12
Dry Contact for Alarm Signal .....	13
Static Pressure.....	13
<b>OUTPUTS .....</b>	<b>14</b>
Output Specifications.....	14
Typical Connection of Triac Outputs 1 to 5.....	15
Typical Connection of Analog Outputs 1 to 3.....	15
<b>POWER SOURCE &amp; NETWORK.....</b>	<b>16</b>
Power Source .....	16
Network Communication.....	16
<b>OVERALL DIMENSIONS.....</b>	<b>17</b>

## GENERAL INFORMATION

### PL-M1000 Heatpump Controller

#### Description

The ProLon PL-M1000 Heatpump controller is a microprocessor-based controller designed to operate residential or commercial heatpump equipment. It uses PI (Proportional-Integral) control loops and acts as a master when used on a network with PL-VC1000 zone controllers.

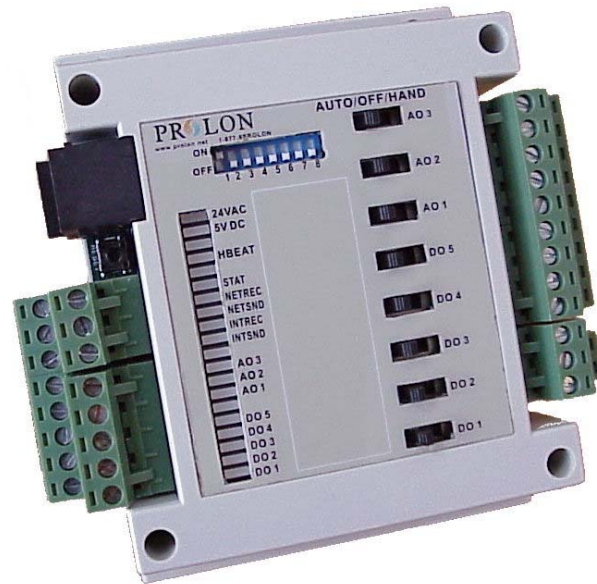

#### General Behaviour

Although fully programmable, the ProLon M1000 Heatpump controller uses pre-established control sequences or "profiles" to operate specific HVAC equipment with dedicated output functions. These can be fully optimized to obtain the best results for each type of system. Numerous parameters enable the modification or fine tuning of the fan, the compressor outputs, the action of the heating outputs (On-or-Off / pulsed / modulating), the proportional bands, integration times, differentials, operational ranges, setpoints and a whole range of limits and safeguards. The various programming options also allow the user to modify the schedule, unoccupied mode settings, morning warm-up and supply air pre-heating sequences as well as the network demand control strategy best suited for the building space it is controlling. All these parameters can be accessed by using the ProLon Focus software or with the ProLon handheld digital interface (PL-HNI).

## Operation Sequence

### General

The ProLon M1000 Heatpump controller receives readings from three different temperature sensors: outside air, return air and supply air. It operates on a configurable schedule using an internal real-time clock. Also, as a Master device, it receives data from the zone controllers sent on the network bus. The controller then analyzes all the data and demands sent by the zones and commands the appropriate outputs to respond accordingly, within parameters set by the temperature sensors and other safety limits. The Master sends back information on its network such as supply air temperature, occupancy status and other relevant data for the zone controllers to use.

### Occupied Mode

The controller operates the fan continuously. When there is a cooling demand from the zones, the Heatpump controller will put the reversing valve into cooling mode and activate the compressor outputs as long as all temperature limits, delays and other related parameters are respected. Once the demand is satisfied, the outputs are deactivated within the prescribed minimum on/off time delays.

When there is a heating demand from the zones and the outside temperature is above the low balance point, the Heatpump controller will put the reversing valve into heating mode and activate the compressor outputs as long as all temperature limits, delays and other related parameters are respected. If the outside temperature is below the low balance point, the controller will activate the auxiliary heating outputs. If the heatpump is configured for water-to-air mode, it will only use the compressor for heating. Once the demand is satisfied, the outputs are deactivated within the prescribed minimum on/off time delays.

When there is no cooling or heating demand from the zones, only the fan operates. If the heating equipment permits, a supply air pre-heating sequence may be enabled. This allows cold mixed air to be heated to a more comfortable level for subsequent use by the zones for ventilation.

## Unoccupied Mode

The fan operates in intermittent mode. When there is a cooling demand from any single zone, the Heatpump controller will activate the fan and the compressor outputs as long as all temperature limits, delays and other related parameters are respected. Once the demand is satisfied, the fan and cooling outputs are deactivated within the min. on/off time delays set.

When there is a heating demand from any zone, the Heatpump controller will activate the fan and the heating outputs as long as all temperature limits, delays and other related parameter are respected. Once the demand is satisfied, the fan and heating outputs are deactivated within the min. on/off time delays set.

During the unoccupied period, the Heatpump controller is driven by the highest demand on the network and will operate the fan and relevant outputs accordingly.

### COMPONENTS

#### Component Identification

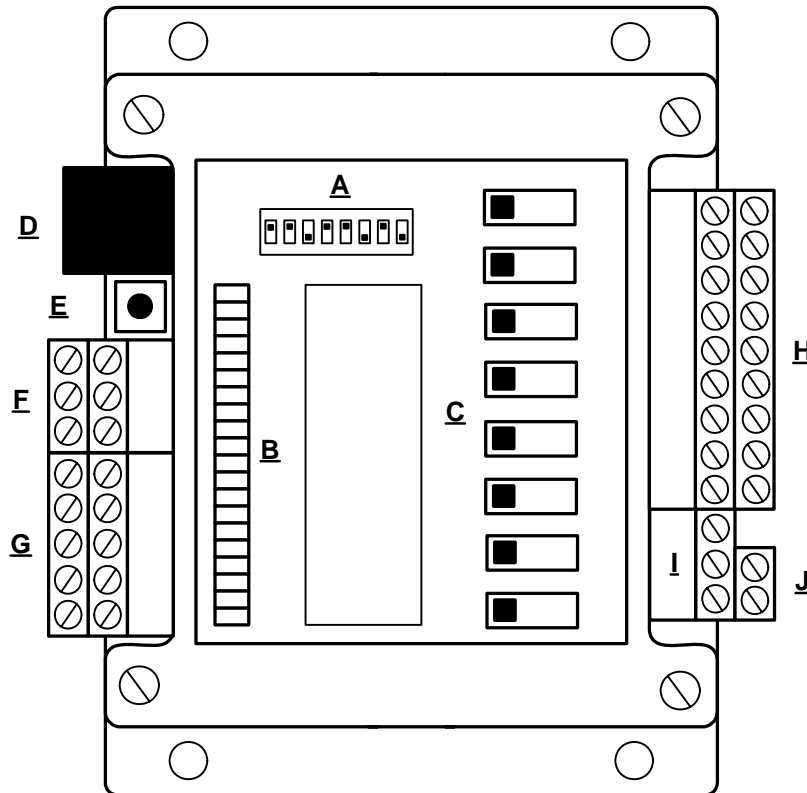

Legend:

- A** = Addressing Dipswitch
- B** = LEDs
- C** = AUTO/OFF/HAND Switches
- D** = RJ45 plugs for Interface Communication
- E** = Master reset button
- F** = Analog outputs
- G** = Digital outputs
- H** = Analog inputs
- I** = Connectors for Network Communication
- J** = Connectors for 24VAC

## LEDs and Switches

The M1000 has an LED block on the front of the casing whose LEDs are linked to different functions and outputs of the controller. Each LED is individually identified to help the user make a quick visual diagnostic of the controller's activity and status.

### LED Descriptions:

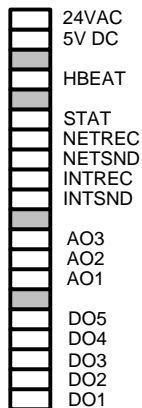

- **24 VAC:** The M1000 is receiving 24 VAC from the power source.
- **5V DC:** The microchip and other components on the M1000 are powered by a 5V DC source successfully derived from the 24VAC source.
- **HBEAT:** When this LED is blinking, the microchip is active and the controller's program is running (normal). When this LED is ON and steady, the M1000 is inactive and the microchip is awaiting programming (you must use ProLon's Focus software to reprogram the microchip).
- **STAT:** When lit, indicates the M1000 is using BACnet communication protocol instead of Modbus on the RS485 communication port.
- **NETREC:** Indicates reception of data from the network communication bus.
- **NETSND:** Indicates transmission of data onto the network communication bus.
- **INTREC:** Indicates reception of data from the interface communication bus.
- **INTSND:** Indicates transmission of data onto the interface communication bus.
- **AO3:** The intensity of the LED represents the voltage present on analog output 3.
- **AO2:** The intensity of the LED represents the voltage present on analog output 2.
- **AO1:** The intensity of the LED represents the voltage present on analog output 1.
- **DO5:** Represents the activity of digital output 5.
- **DO4:** Represents the activity of digital output 4.
- **DO3:** Represents the activity of digital output 3.
- **DO2:** Represents the activity of digital output 2.
- **DO1:** Represents the activity of digital output 1.

### HAND/OFF/AUTO Switches

Each output on the M1000 has a dedicated switch that lets the user manually override the activity of the output. "HAND" mode (switch at leftmost position) fully activates the output (24 VAC for digital outputs, 10VDC for analog outputs). "OFF" (switch at center) deactivates the output and "AUTO" (switch at right) returns control of the output to the program in the M1000's microchip.

### Internal Jumpers

The M1000 has several sets of jumpers on the lower internal board that permit the configuration of various hardware elements (see Figure 1).

**RJ45:** The RJ45 jumper lets the user select the voltage that will appear on pin #7 of the RJ45 plug. This can be used to power a device attached to the RJ45 plug, such as the PL-HNI digital interface. **NOTE:** If multiple M1000 controllers are connected together through the RJ45 plug, only one M1000 should be supplying power onto the RJ45, otherwise you will be mixing your supply sources and possibly cause damage. The jumper setups are as follow

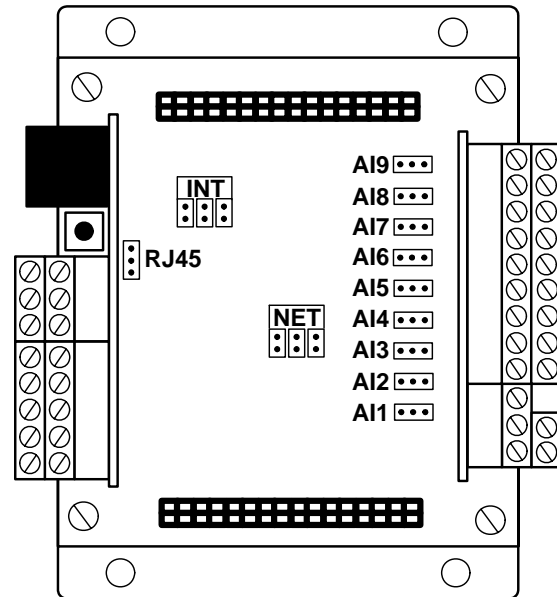
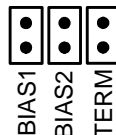
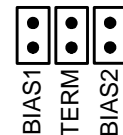

Figure 1: Location of internal jumpers

**INT:** These are the jumpers for the bias and terminating resistors used for the interface communication bus. See the ProLon network guide for information about bias and terminating resistors.



**NET:** These are the jumpers for the bias and terminating resistors used for the network communication bus. See the ProLon network guide for information about bias and terminating resistors.



**AI 1 - 9:** These jumpers allow the user to select the signal mode of the associated analog input.

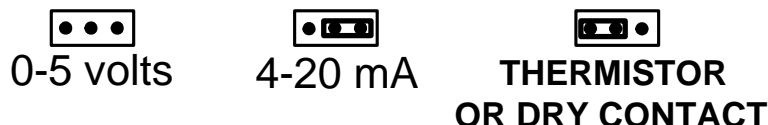



### Input and Output Identification

All the inputs and outputs of the controller use "Plug-In" type screw connectors. The connectors used for interface communication and programming are dual RJ45 type connectors, which are wired in parallel with each other (one in, one out). With these connectors, the wiring can be done quickly and much more easily.

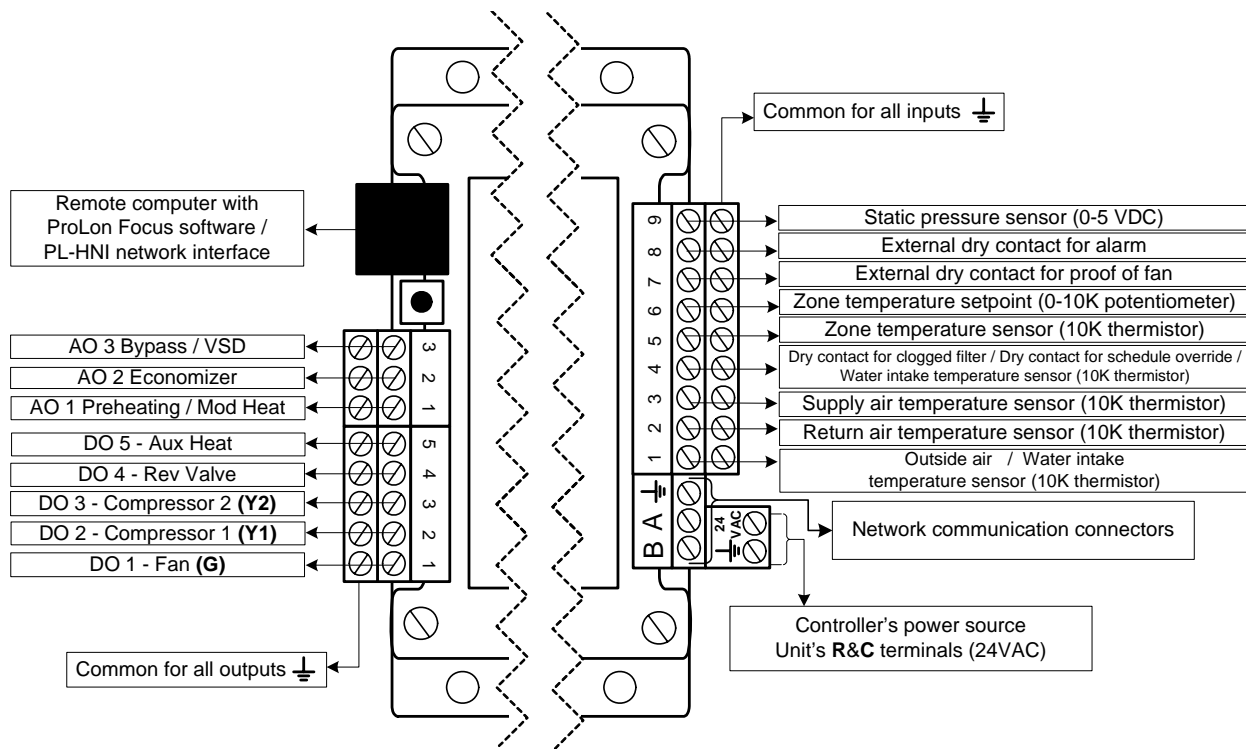

### Addressing Dipswitch Configuration for Network Communication

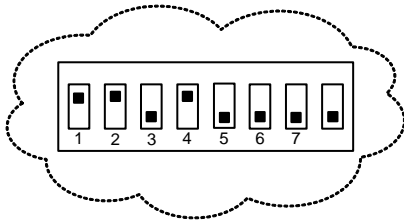

**Figure 2: Addressing Dipswitch**

For proper communication, a unique address must be configured on each controller by setting the first 7 switches on the addressing dipswitch to the desired value.

These switches are numbered from 1 to 7 and represent a binary value from 1 to 64 (1, 2, 4, 8, 16, 32, and 64 respectively). The last switch (#8) is reserved. The value of each switch that is in the ON position is added together to form the numerical address of the controller.

The example in Figure 2 shows the switches 1, 2 and 4 in the ON position. Therefore, the corresponding values are 1, 2 and 8, giving an address sum of 11.

The ProLon network allows a maximum of 127 addresses, therefore 127 controllers.

### INPUTS

#### Temperature Sensors

The M1000 Heatpump controller has three analog inputs that monitor outside air, supply air and return air temperatures (see Figure 3) and will integrate these readings into its control sequence. The sensors used are standard 10k type thermistors that share a single common connection. Alternatively, the supply air temperature can be retrieved from a slave that has a supply sensor and is located on the Masters network.

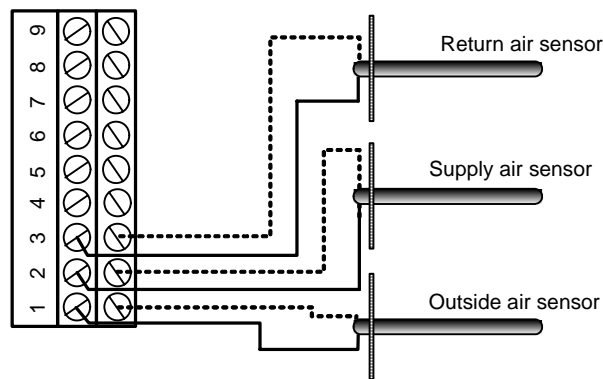

Figure 3: Connecting the temperature sensors

#### Room Sensors

The M1000 can receive the setpoint and temperature from a specific room when a PL-RSC analog thermostat is connected to it. The M1000 will then automatically integrate this information into its control sequence. The setpoint may also simply be set by software. The PL-RSC series room sensors are connected using a 3-conductor cable (see Figure 4).

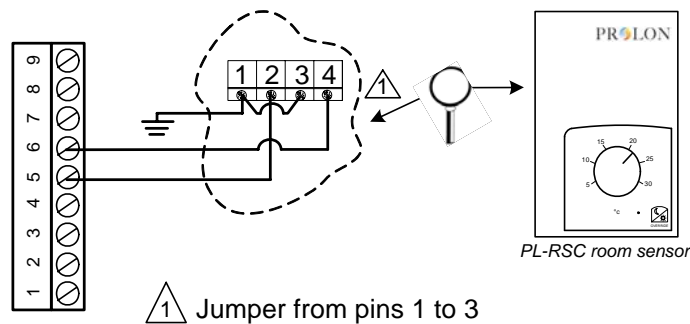

Figure 4: Typical wiring of the PL-RSC room sensor to the controller

### Proof of Fan

The M1000 has an analog input dedicated to the proof of fan signal. Please refer to Figure 5 to see how to correctly connect it to analog input 7. To indicate proof of fan, the contact must be closed. If no proof of fan signal is available, you must short analog input 7, or else the controller will interpret the absence of signal as a fan malfunction and no heating or cooling action will be taken.

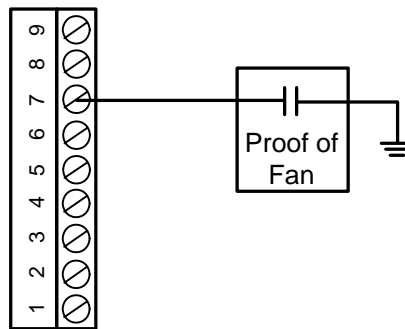

Figure 5: Connecting the proof of fan contact to the controller

### Dry Contact for Clogged Filter or Schedule Override

Analog input 4 on the M1000 can also be configured as a dry contact input for either a clogged filter sensor or as a schedule override input. Please refer to Figure 6 to see proper connection.

- Clogged filter sensor: To indicate that the filter is clogged, the contact must be closed.
- Schedule Override: Closing the contact causes the M1000 to immediately return to occupied mode from unoccupied mode. The M1000 remains in occupied mode as long as the contact is held closed. If it was already in occupied mode, there is no change.

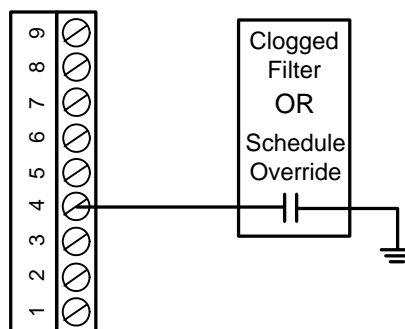
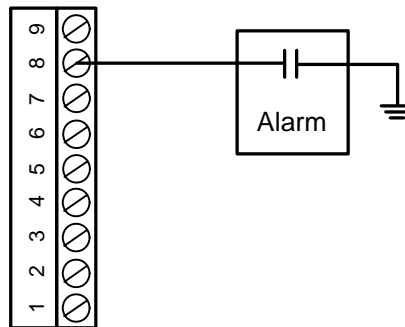

Figure 6: Connecting the dry contact input to the controller

## Dry Contact for Alarm Signal

The M1000 has an analog input dedicated to an alarm signal. Please refer to Figure 7 to see how to correctly connect it to analog input 8. To signal an alarm, the contact must be closed. This input does not affect the sequences of the M1000, and is only used to inform the user through the visualisation software or the digital interface



**Figure 7: Connecting the alarm contact to the controller**

## Static Pressure

Analog input 9 on the M1000 rooftop controller is dedicated to a static pressure sensor. By default, a 0-5 VDC signal is expected for the static pressure input. However, this can be modified using the internal jumpers (see p.8). Please refer to Figure 8 for correct wiring.

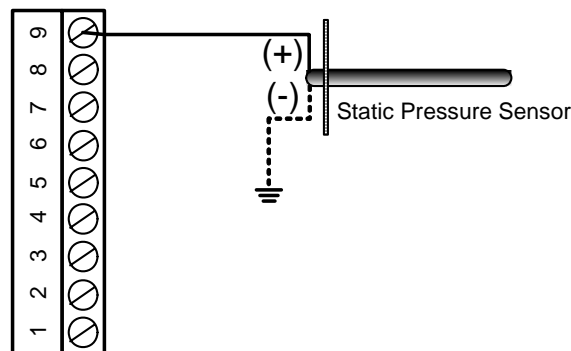

**Figure 8: Connecting pressure sensors**

## OUTPUTS

The M1000 Heatpump controller contains 8 customizable outputs; five triac ON/OFF outputs (24VAC) and three analog outputs (0-10VDC). Output configuration is performed via the ProLon Focus software or the PL-HNI digital interface.

An integrated resettable fuse protects each of the outputs of the M1000 against current surges and short circuits. This protection will cut the current to the output as soon as an overload condition is detected. The fuse is a round, yellow-coloured PTC that will change to orange and heat up on a overload condition. Once current has been removed from the output, the fuse will cool down and automatically reset. Fix the faulty wiring and you will be able to activate the output once again.

### Output Specifications

Output	Type	Action	Application
DO 1	Triac source 24VAC Max Current: 750 mA	On-or-Off	Fan (G)
DO 2	Triac source 24VAC Max Current: 750 mA	On-or-Off	Compressor (1st Stage) (Y1)
DO 3	Triac source 24VAC Max Current: 750 mA	On-or-Off	Compressor (2nd Stage) (Y2)
DO 4	Triac source 24VAC Max Current: 750 mA	On-or-Off	Reversing Valve
DO 5	Triac source 24VAC Max Current: 750 mA	On-or-Off	Auxiliary Heat
AO 1	Configurable Analog Output: - 0 to 10 VDC - 2 to 10 VDC - 0 to 5 VDC Max Current: 50 mA	Modulating proportional <b>OR</b> Pulsed <b>OR</b> On-or-Off	Preheating only <b>OR</b> Preheat + Heating <b>OR</b> Heating
AO 2	Configurable Analog Output: - 0 to 10 VDC - 2 to 10 VDC Max Current: 50 mA	Modulating proportional	Economizer
AO 3	Configurable Analog Output: - 0 to 10 VDC - 2 to 10 VDC Max Current: 50 mA	Modulating proportional	Bypass <b>OR</b> Variable Frequency Drive

### Typical Connection of Triac Outputs 1 to 5

On the M1000 Heatpump controller, all triac outputs produce a 24 VAC live voltage when activated. Note that all output voltages originate from a single voltage supply: the equipment's transformer. Consequentially, only the live side of the output connections are usually needed; these are on the top row (see Figure 9). The bottom row is the common (GND).

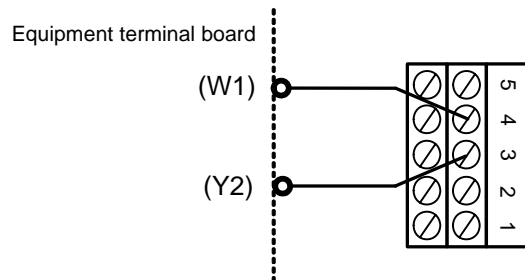

Figure 9: Connection of digital outputs 3 and 4

### Typical Connection of Analog Outputs 1 to 3

For all analog outputs, the common is found on the bottom row of connectors, and the active signals are found on the top row of connectors (see Figure 10). Analog output 1 can be configured to modulate a 0-10 VDC load, to pulse a 0 or 10 VDC triac relay or to control a 10 VDC On/Off relay. Analog outputs 2 can only modulate a DC load (0-10 VDC or 2-10 VDC).

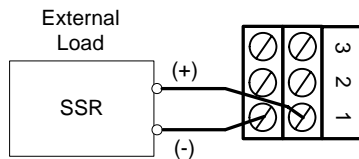

Figure 10: Connecting the analog output 1 (external power)

### POWER SOURCE & NETWORK

#### Power Source

The M1000 controller is powered by the HVAC equipment's 24 VAC power supply by connecting the common ("C" wire) to the "COM" pin and the live ("R" wire) to the "24 VAC" pin (see Figure 11). The common for all inputs and outputs is the same as the power source's common. All output power sources also originate from the HVAC equipment's power source.

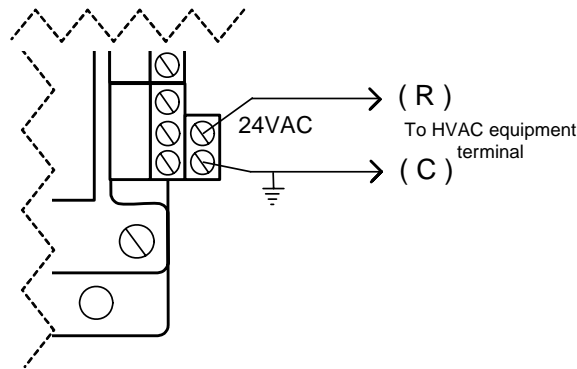

Figure 11: Connecting the 24VAC power source

#### Network Communication

The ProLon M1000 Heatpump controller is designed to work with the VC1000 zone slaves. When they are networked, the Master and slaves all communicate in real-time. The network connections are made using the network pins located on the M1000 controller (see Figure 12).

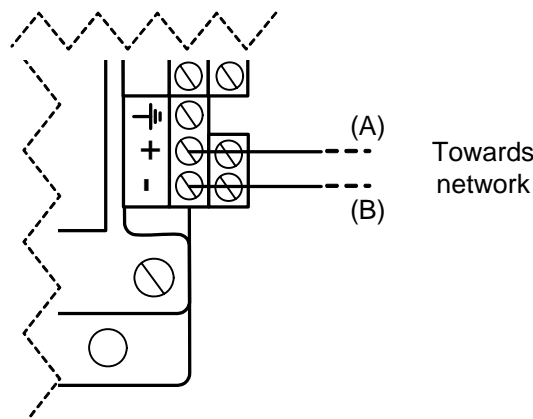
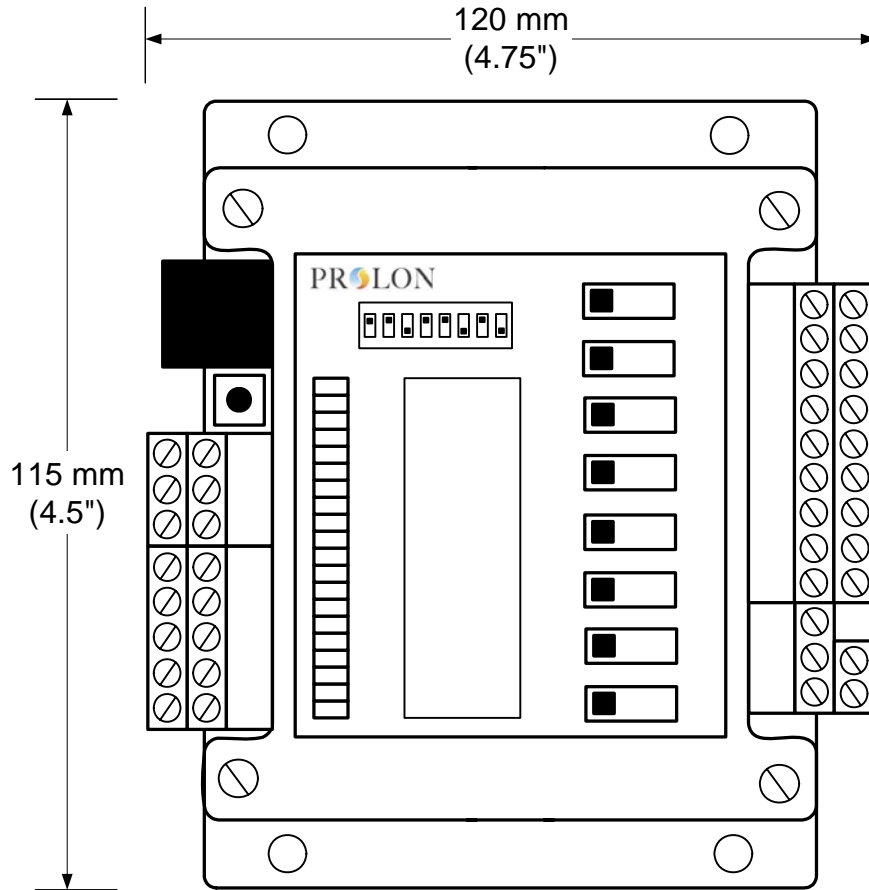

Figure 12: Connecting to the network



### OVERALL DIMENSIONS



© Copyright 2010 ProLon. All rights reserved.

No part of this document may be photocopied or reproduced by any means, or translated to another language without prior written consent of ProLon.

All specifications are nominal and may change as design improvements are introduced. ProLon shall not be liable for damages resulting from misapplication or misuse of its products. All other trademarks are the property of their respective owners.

[info@prolon.net](mailto:info@prolon.net)

[www.prolon.net](http://www.prolon.net)

# PROLON

1-877-9PROLON

**Montréal**

1989 rue Michelin Laval,  
QC H7L 5B7

TEL: (450) 973-7765 FAX: (450) 973-6186  
1-800-461-1381